

DETAIL A

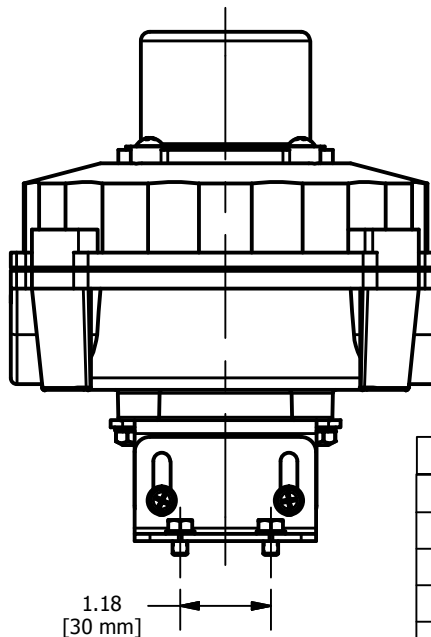
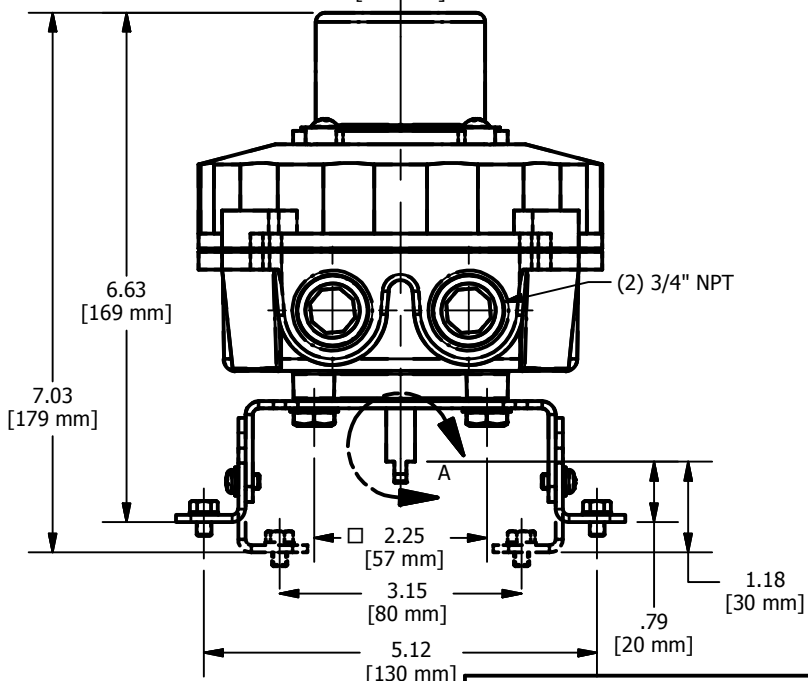
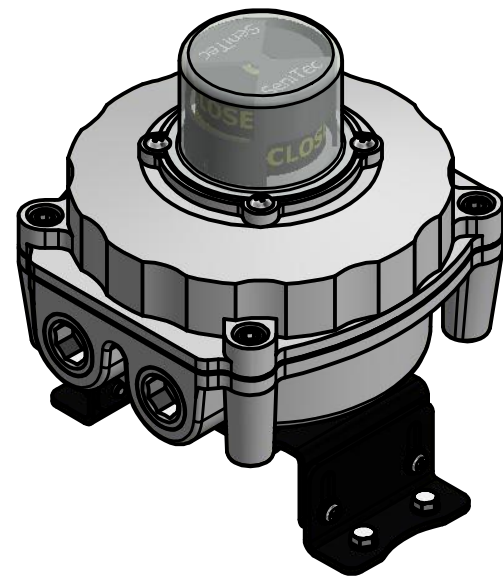

LABAH211100	
Enclosure Type	Nema 4, 4x IP67
Switch Type	(2) QA23 Magnet Sensor
Switch Voltage	5-240 VAC/VDC <= 300mA
Terminal Strip	8 Pole
Indicator	Black and Yellow
Universal Bracket	Namur Standard Included

DESCRIPTION  
**Specification Sheet**  
**Unitorq L Series Switch Box**  
**Envelope and Mounting**  
**Dimensions**

NOTICE:  
 THIS DRAWING INCLUDES THE DESIGN AND PRINCIPLES DISCLOSED AND IS THE SOLE PROPERTY OF UNITORQ AND ITS AFFILIATES. IT SUBMITTED WITH THE UNDERSTANDING THAT IT IS NOT TO BE REPRODUCED, NOR COPIED IN WHOLE OR IN PART, NOR LOANED OR OTHERWISE COMMUNICATED TO ANY THIRD PARTY, NOR USED IN ANY MANNER DETRIMENTAL TO THE INTERESTS OF UNITORQ OR ANY OF ITS AFFILIATES WITHOUT THE EXPRESSED WRITTEN CONSENT OF UNITORQ. ACCEPTANCE OF THIS DRAWING WILL BE CONSTRUED AS AN AGREEMENT TO THE ABOVE.



2150 Boggs Road, Suite 410  
 DULUTH, GEORGIA U.S.A. 30096  
 Ph: 770-446-7074  
 Fax: 770-447-1825  
 www.unitorq.com



PRODUCT: Switch Box	PART NUMBER: LABAH211100	SALES DRAWING NUMBER: LABAH211100	DWN BY: KLE	DATE: 11/23/2022	SCALE: NTS	REV. 0
------------------------	-----------------------------	--------------------------------------	----------------	---------------------	---------------	-----------